

The WLF-44 louvre window is suitable for natural ventilation or natural smoke (NSHEV) applications. Designed on the solidity of our WL range, but incorporating 'frameless' louvre blades for a full glass external appearance.

- For natural or natural smoke (NSHEV) applications.
- 44mm triple glazing
- No external framing for complete glass look.
- Insulated panel option.
- RC2 security rated.
- For installation in vertical facades
- Frame and sash profiles are thermally separated, made from composite of aluminium and PA6.6 / PT profiles
- Standard with 64° opening angle, up to 90° if required



EN12101-2 certified



'Frameless' external appearance.



RC2 security rated



Triple glazed or aluminium panel infill

WLF-44 Certifications & Test Data	
Glazing Panel Thickness	44mm
Glazing Types	44mm Triple Glazed or Insulated Panel
Frame Depth	600mm (+25mm on driven side)
Perimeter Frame Width	38mm
Unit Width	300-2500mm
Max Frame Height	Unlimited (sections)
Louvre Height	120-400mm
Louvre Blade Framing	33mm (behind external glass)
EN12101-2:2003	
Aerodynamic free area	Individual Calc.
Wind Load	WL 2500
Low Ambient Temperature	T (-20)
Reliability Class	Re 1000
Snow Load	SL 0
Resistance to heat	B 300-E
EN14351-1	
Air Permeability (EN12207)	Class 6A (7A with additional seal)
Watertightness (EN12208)	Class 3 (Class 4 with additional seal)
Wind Load Class (EN12210/12211)	Class C2 (Class C5 with additional seal)
Durability (DIN EN 1191)	Class 3
Heat Transition Co-efficient (EN ISO 10077-1)	Individual calc.
Sound Reduction (DIN EN ISO 717-1)	Up to 38dB
Fall Protection (DIN EN 18008-4)	✓
Ball Safety (DIN EN 18032:1997)	✓
Security Rating (EN1627-1630)	RC2





WLF-44

Construction

- Louvre windows for installation in vertical facades
- Thermally broken frame and sash profiles manufactured from extruded aluminum and PA6.6 / PT profiles.
- Louvre blades consist of double insulating glazing.
- Insulated PPC aluminium skinned panel option.
- Louvre windows consist of one or more stacked louvres, which open on a central pivot. As a rule, the axis of rotation is in the middle of the louvre, but can also be modified up to 1/3 - 2/3 after technical clarification.
- Standard with 64° opening angle, up to 90° if requested.

Profile Dimensions

- Frame depth: 60 mm
- Perimeter frame width: 38 mm
- Louvre blade frame width: 33mm (behind external glass).

Seals

- Vertical brush seals
- Horizontal profile glass joints with silicone seal

Fixings

- All unit fittings are concealed
- Made of corrosion-free or galvanised materials

Finishes

- Profiles can be anodised, powder coated or wet paint coated in RAL or special colours.
- Standard PPC to 40 Microns unless otherwise stated.

Applications

- Natural ventilation
- NSHEV certified to DIN EN 12101-2 for natural smoke ventilation
- For installation in vertical facades (further applications after technical clarification)

Size Range

- Minimum frame width: 300 mm
- Maximum frame width: 2500mm
- Units exceeding maximum width will be supplied as 2 units, joining together on site.
- Louvre blade height variable: 120 mm to 400 mm

Control Option	Notes
Manual Hand Lever	
Articulated Crank Rod	
230V AC	
24V DC	Suitable for NSHEV (EN12101-2)
24V DC with SK3 anti-trapping	Suitable for NSHEV (EN12101-2)
24V DC with SK3 anti-trapping & 10 year battery backup for auto close/open	Suitable for NSHEV (EN12101-2)
Pneumatic Cylinder	Suitable for NSHEV (EN12101-2)



Framing Options

Our WLF range is available with a number of different control and framing options to suit most applications. Bespoke options are available.

Standard framing

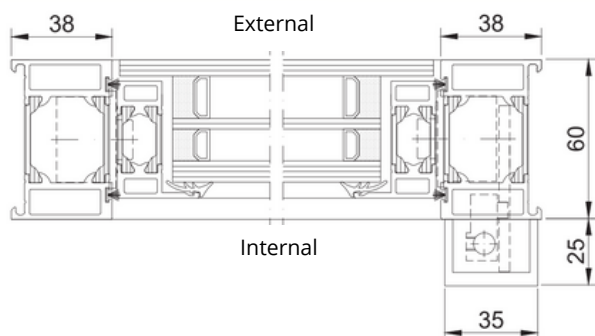

Vertical Section (no motor shown)

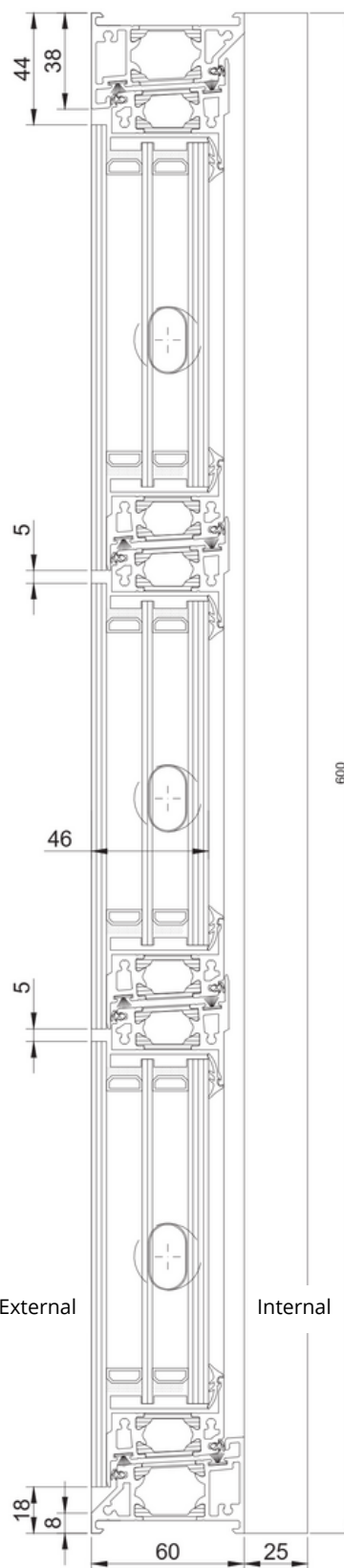

Extended framing (allowing space for internal finish)

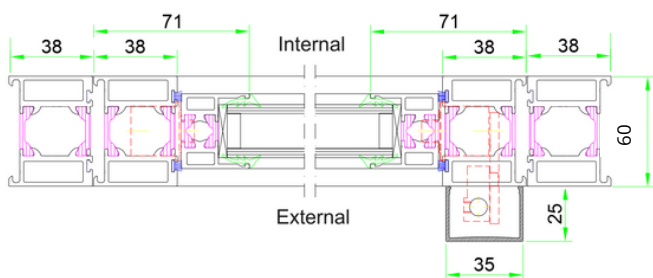

30mm Glazing Adapter

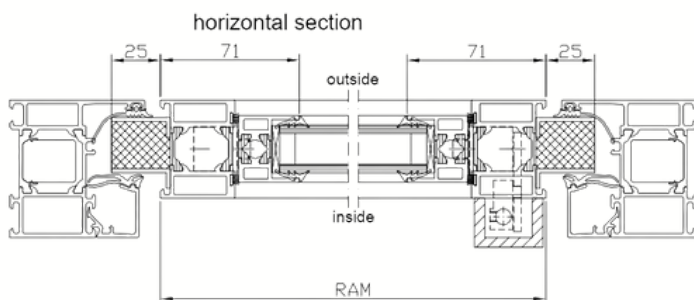

20mm Curtain Walling Adapter

