

The WLF-36 louvre window is suitable for natural ventilation or natural smoke (NSHEV) applications. Designed on the solidity of our WL range, but incorporating 'frameless' louvre blades for a full glass external appearance.

- For natural or natural smoke (NSHEV) applications.
- 36mm double/triple glazing
- No external framing for complete glass look.
- Insulated panel option.
- For installation in vertical facades
- Frame and sash profiles are thermally separated, made from composite of aluminium and PA6.6 / PT profiles
- Standard with 78° opening angle, up to 90° if required



EN12101-2 certified



'Frameless' external appearance.



See below for framing and motor types



Double/triple glazed/  
aluminium panel infill

WLF-36 Certifications & Test Data	
Glazing Panel Thickness	36mm
Glazing Types	36mm Double/Triple Glazed/Insulated Panel
Frame Depth	50mm (+25mm on driven side)
Perimeter Frame Width	38mm
Unit Width	300-2000mm
Max Frame Height	Unlimited (sections)
Louvre Height	120-400mm
Louvre Blade Framing	33mm (behind external glass)
<b>EN12101-2:2003</b>	
Aerodynamic free area	Individual Calc.
Wind Load	WL 2500
Low Ambient Temperature	T (-20)
Reliability Class	Re 1000
Snow Load	SL 0
Resistance to heat	B 300-E
<b>EN14351-1</b>	
Air Permeability (EN12207)	Class 4A
Watertightness (EN12208)	Class 3
Wind Load Class (EN12210/12211)	Class C2
Durability (DIN EN 1191)	Class 3
Heat Transition Co-efficient (EN ISO 10077-1)	Individual calc.
Sound Reduction (DIN EN ISO 717-1)	Up to 38dB
Fall Protection (DIN EN 18008-4)	✓
Ball Safety (DIN EN 18032:1997)	✓





# WLF-36

## Construction

- Louvre windows for installation in vertical facades
- Thermally broken frame and sash profiles manufactured from extruded aluminum and PA6.6 / PT profiles.
- Louvre blades consist of double insulating glazing.
- Insulated PPC aluminium skinned panel option.
- Louvre windows consist of one or more stacked louvres, which open on a central pivot. As a rule, the axis of rotation is in the middle of the louvre, but can also be modified up to 1/3 - 2/3 after technical clarification.
- Standard with 78° opening angle, up to 90° if requested.

## Profile Dimensions

- Frame depth: 50 mm
- Perimeter frame width: 38 mm
- Louvre blade frame width: 33 mm

## Seals

- Vertical brush seals
- Horizontal profile glass joints with silicone seal

## Fixings

- All unit fittings are concealed
- Made of corrosion-free or galvanised materials

## Finishes

- Profiles can be anodised, powder coated or wet paint coated in RAL or special colours.
- Standard PPC to 40 Microns unless otherwise stated.

## Applications

- Natural ventilation
- NSHEV certified to DIN EN 12101-2 for natural smoke ventilation
- For installation in vertical facades (further applications after technical clarification)

## Size Range

- Minimum frame width: 300 mm
- Maximum frame width: 2000mm
- Units exceeding maximum width will be supplied as 2 units, joining together on site.
- Louvre blade height variable: 120 mm to 400 mm

Control Option	Notes
Manual Hand Lever	
Articulated Crank Rod	
230V AC	
24V DC	Suitable for NSHEV (EN12101-2)
24V DC with SK3 anti-trapping	Suitable for NSHEV (EN12101-2)
24V DC with SK3 anti-trapping & 10 year battery backup for auto close/open	Suitable for NSHEV (EN12101-2)
Pneumatic Cylinder	Suitable for NSHEV (EN12101-2)



# Framing Options

Our WL range is available with a number of different control and framing options to suit most applications. Bespoke options are available.

## Standard framing

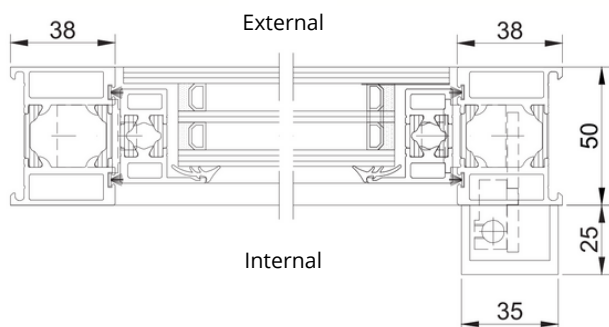

## Extended framing (allowing space for internal finish)

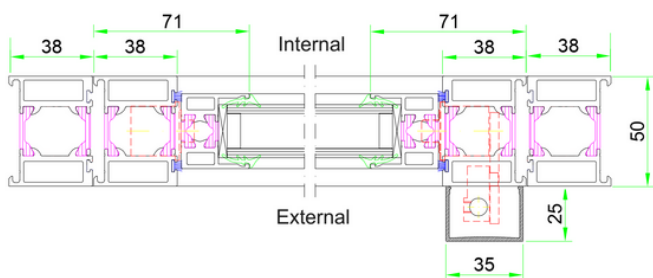

## 30mm Glazing Adapter

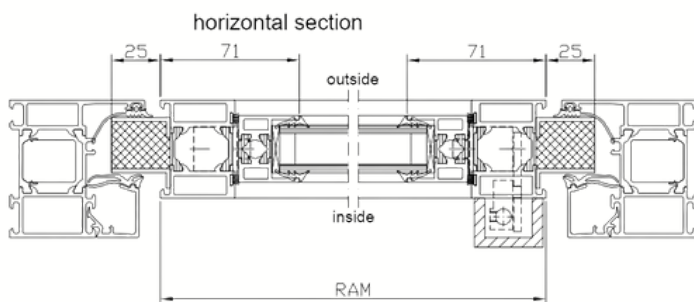

## 20mm Curtain Walling Adapter

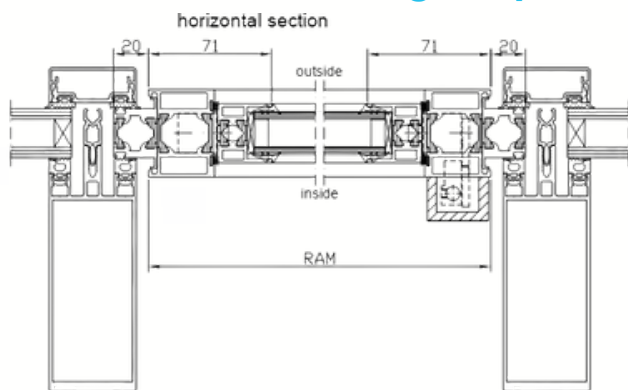

## Vertical Section (no motor shown)

